

Middleware Solutions for Self-organizing Multi-hop Multi-path Internet Connectivity Based on Bluetooth

Paolo Bellavista
Carlo Giannelli

29.4.2009

DEIS, Università degli Studi di Bologna,
Viale Risorgimento, 2 - 40136 Bologna Italy
carlo.giannelli@unibo.it



Agenda

- From traditional homogeneous to novel **heterogeneous** wireless scenarios
 - several communication technologies
 - infrastructure and **peer** points of access
- **Multi-hop Multi-path Heterogeneous Connectivity (MMHC) middleware for **context-aware** dynamic connectivity in **heterogeneous environments**
 - context information related to path reliability and throughput
 - manage interface, platform, driver **heterogeneity**
 - **efficiency required** to gather context information, evaluate connectivity opportunities, and perform connections**



The Wireless Scenario

- **Client node:** node **requiring** connectivity, e.g., user PDA
- **Connectors:** nodes **providing** connectivity, e.g., UMTS base station
- **Channel:** active client-connector IP connection, e.g., Bluetooth pairing and DHCP configuration

- **Handover procedure**
 - a client node **changes** current **connector** while moving
- **Evaluation process**
 - **context gathering:** which information is important?
 - **metric application:** which is the most suitable connector?

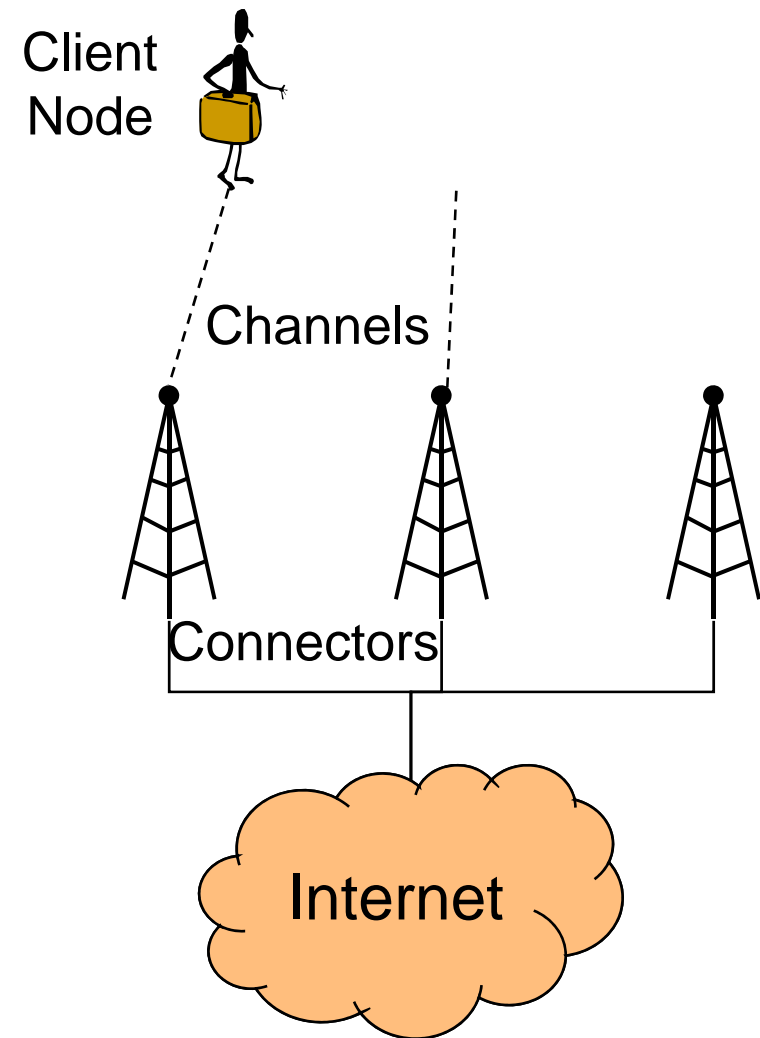



Homogeneous Wireless Scenario

- **One communication interface** at a time
 - the client node does not change wireless interface
- **Horizontal handover**
 - infrastructure connectors only
 - origin and destination connectors based on the same wireless technology
- **IEEE 802.11**
 - connectors are IEEE 802.11 Access Points (APs)
 - metric based on Received Signal Strength Indication (RSSI) and Signal to Noise Ratio (SNR), usually embedded in interface firmware



Heterogeneous Wireless Scenario

■ Heterogeneous interfaces

- the client node exploits **multiple wireless** interfaces, even simultaneously

■ Heterogeneous connectors

- **infrastructure** or **peer** nodes
- fixed or **mobile** peers
- single-/**multi-hop** paths

■ Connectivity management

- managing interfaces/connectors/channels/paths considering **several context data** to take advantage of the **many networking opportunities**

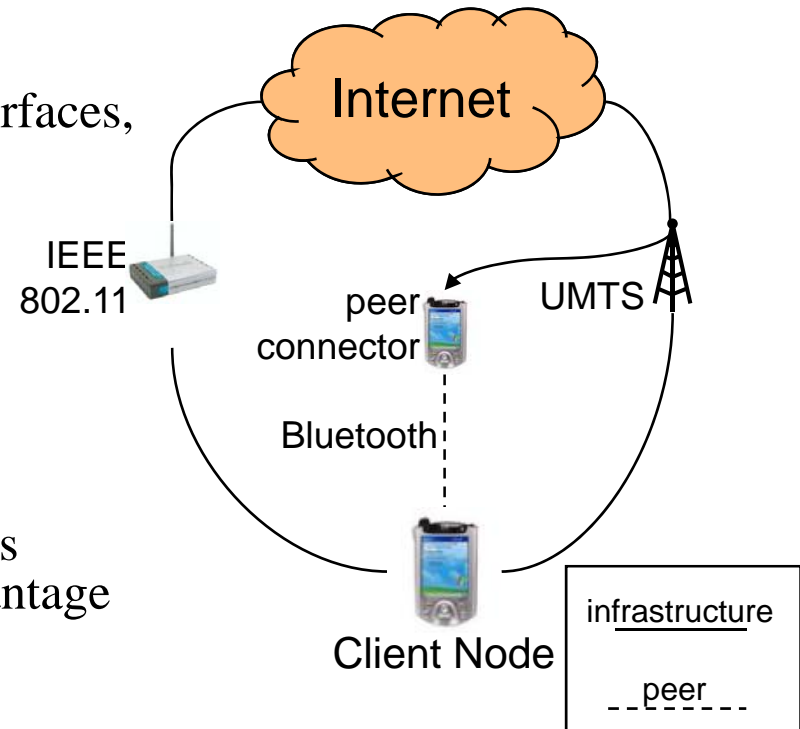

■ Wireless heterogeneity increases client node capabilities:

- heterogeneous connectors enable the **most suitable** form of connectivity
 - Bluetooth to limit power consumption, IEEE 802.11 to get larger bandwidth
- peer connectors **extend connectivity** opportunities via multi-hop **paths**
 - UMTS link accessed via Bluetooth through a peer connector



MMHC: Multi-hop Multi-path Heterogeneous Connectivity

- Novel metric considering a wide set of information at different abstraction levels
 - traditional RSSI/SNR based evaluation processes are not enough
- **Evaluation metric** specifically designed for heterogeneous wireless scenarios
 - client node and peer **mobility** (based on RSSI) to provide **reliability**
 - wireless technology and path characteristics, e.g., bandwidth and number of clients at each hop, to provide **sufficient throughput**
 - **residual battery** level to ensure path **long-term durability**



MMHC Architecture

- Network Interface Provider
 - **homogeneous access to heterogeneous interfaces** on different operating systems
- Connector Manager
 - **single-hop connections** based on node mobility
- Routing Manager
 - context information **remote distribution**
 - **multi-hop paths** based on estimated connectivity availability and throughput

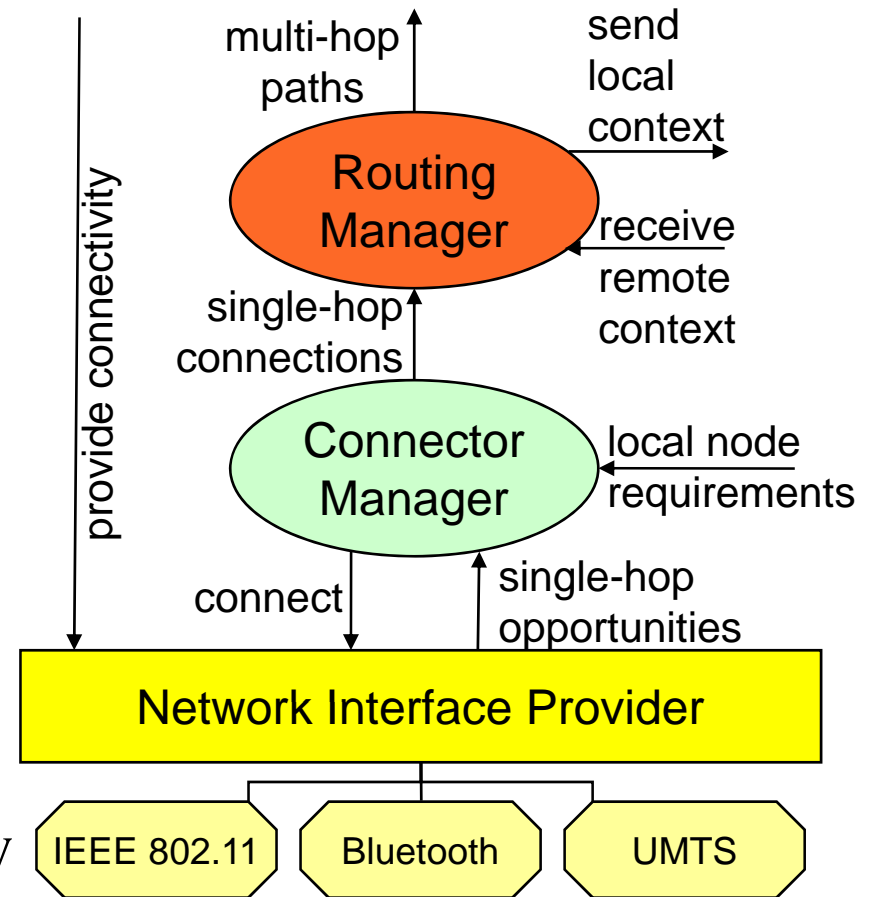



Network Interface Provider

- Network Interface Provider (NIP) provides a homogeneous access to heterogeneous interfaces
- **Features:** set of capabilities common to interfaces
 - **get available connectors**, to get available connectors list and related information such as RSSI
 - **perform as peer connector**, to offer connectivity in a peer-to-peer fashion
 - **connect to a connector**, to perform a connection with a given connector
- IEEE 802.11 standard
 - **scan** of available ESSID (Extended Service Set ID)
 - connectivity provisioning via **IBSS** (Independent Basic Service Set)
 - **association** to a given AP

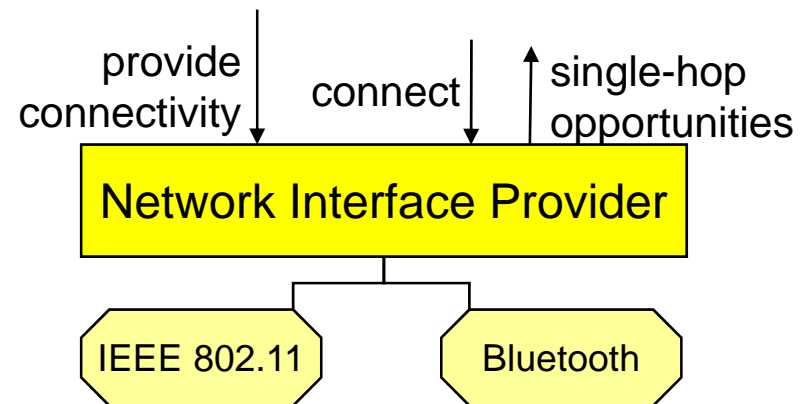



Connector Manager

- Connector Manager (CM) establishes **single-hop channels** with remote devices
 - 1) connectors discovery via **any interface**
 - 2) **connectors evaluation** based on **mobility degree**
 - 3) requires **layer2 connections** with most suitable connector of each interface
 - 4) activates layer3 configuration via **DHCP client**

- CM does not interact with remote nodes
 - mobility degree achieved **locally** in a lightweight manner
 - requirements in terms of maximum node-connector mutual mobility

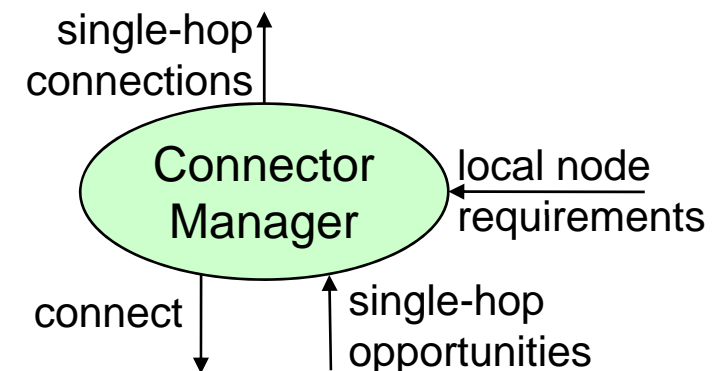



Routing Manager

- Routing Manager (RM) handles **multi-hop paths**
 - 1) **context information exchange** with one-hop distant nodes
 - 2) single-hop distant **links evaluation**
 - 3) **routing rule modification** to provide suitable multi-hop paths
- RM has a **wider perspective**
 - mobility, throughput and energy of paths
 - **discard unreliable paths** due to mobility, then achieve a trade-off among **throughput and energy**

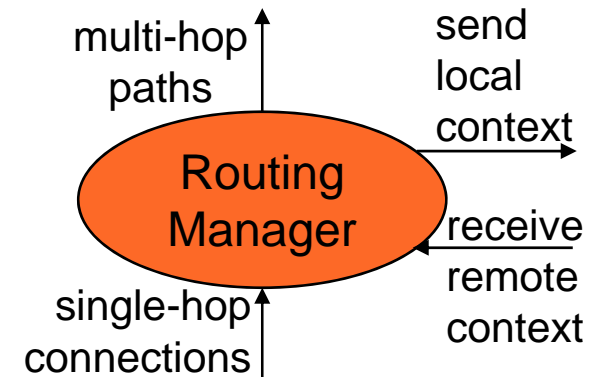



Performance Considerations (1)

- Operating system and wireless interface **independent** tasks
 - **little impact** on achieved performance
 - e.g., CM spends about 120ms for the dynamic evaluation of 5 connectors
- **Operating system dependent** tasks
 - **different implementations** on different platforms
 - e.g., RM performs multi-hop path creation via `iptables` on Linux and `route` on MS Windows



Performance Considerations (2)

- **Wireless interface dependent tasks**
 - **different implementations** on different platforms and different drivers
 - IEEE 802.11: Wireless Extensions on Linux, NDIS drivers on Windows XP/Vista
 - Bluetooth: BlueZ on Linux, Widcomm , BlueSoleil and Microsoft Bluetooth Stack on Windows XP/Vista
 - **great impact on performance**
 - IEEE 802.11 AP scan and association last about 1-3s, in relation to underlying devices
 - Bluetooth inquiry procedure and pairing last more than 12s



MMHC Scenarios and Bluetooth

- Bluetooth usually exploited only to connect remote devices, e.g., wireless keyboard/mouse
 - manual connection via platform specific user interfaces
 - relatively long pairing procedure
 - limited coverage range

- Bluetooth suitable also for **connectivity provisioning**
 - much **lower power consumption** than IEEE 802.11
 - 1-35 mA instead of 100-350 mA
 - **sufficient bandwidth** for many applications
 - 0.7 Mbps for Bluetooth 1.2, 3 Mbps for Bluetooth 2.0 EDR



NIP and Bluetooth

- NIP implementation for Bluetooth
 - get available connectors, **inquiry procedure** to discover Bluetooth devices
 - perform as peer connector, **PAN** (Personal Area Network) provisioning and **DHCP server** instantiation
 - connect to a connector, **PAN** connection and **DHCP client**
- Bluetooth-specific issues:
 - manage driver **heterogeneity**
 - increase inquiry **efficiency**
- JSR-82 exploitation to provide a **platform independent efficient implementation** of NIP features for Bluetooth devices



JSR-82: Java APIs for Bluetooth

■ Pros

- **multi-platform** standard
- applications can **reduce the inquiry period**

■ Cons

- do **not provide RSSI** values, required to evaluate connectors mobility
- do **not support BNEP** (Bluetooth Networking Encapsulation Protocol), required to easily provide IP-based PAN connectivity

■ Note: NIP and JSR-82 act at different layers

- **NIP** provides homogeneous access to **heterogeneous interfaces**, e.g., IEEE 802.11 and Bluetooth
- **JSR-82** provides homogeneous access to **heterogeneous drivers** for Bluetooth, e.g., BlueZ and MS Bluetooth Stack

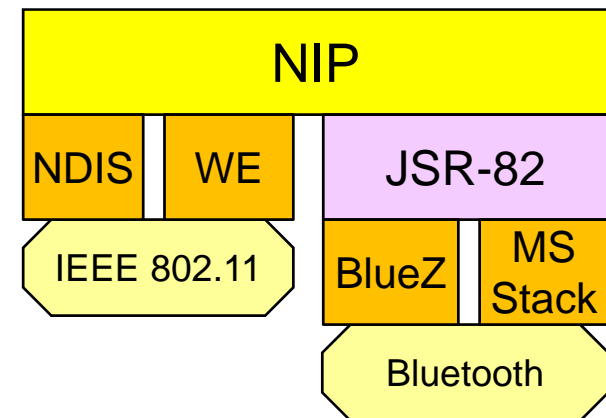



Adaptable Inquiry Procedure

- JSR-82 DiscoveryAgent class: startInquiry and cancelInquiry methods
 - full inquiry procedure of 10.24s discovers 100% devices
 - **halved inquiry** procedure of 5.12s discovers **99% devices** [Peterson et al.]
- Connector Manager (CM) modifies inquiry procedure length in relation to the current context
 - **short inquiry** at system startup and at **connectivity disruption**
 - full inquiry otherwise



JSR-82 Extension for RSSI Gathering

- Bluetooth provides RSSI only of connected devices
 - 1) inquiry procedure to discover devices
 - 2) **baseband connection**
 - 3) RSSI gathering

- Linux BlueZ
 - `hcitool -i hciX cc remote_addr`
 - `hcitool -i hciX rssi remote_addr`

- Windows Widcomm
 - `BOND_RETURN_CODE Bond(BD_ADDR bda, BT_CHAR *pin_code)`
 - `BOOL GetConnectionStats(BD_ADDR bda, tBT_CONN_STATS *p_conn_stats)`



JSR-82 Extension for Connectivity Provisioning (1)

- additional BNEPConnector class: `server()` method
 - setup a Group Ad-hoc Network (GN) PAN: a device behaves as gateway, the others as clients
 - instantiate a DHCP server: the node acts as gateway
- Linux BlueZ
 - `pand -i hciX --listen --role GN --devup ./devup.sh --master`
 - `devup.sh` instantiates the **DHCP server** at connection establishment, as soon as `bnepX` interface is available
- Windows Widcomm
 - no PAN setup, no DHCP server command (available on MS Windows Server 2008)



JSR-82 Extension for Connectivity Provisioning (2)

- 1) NIP exploits `BNEPConnector.client(remote_addr)` to connect to a GN PAN as PANU (PAN User)
 - Linux BlueZ: `pand -i hciX --connect remote_addr --role PANU --service GN`
 - Windows Widcomm: `CreateConnection(remote_addr, SERVCLASS_GN)`
- 2) Then NIP activates a DHCP client
 - Linux: `dhclient` on `bnepX` interface
 - Windows: `ipconfig /renew *`

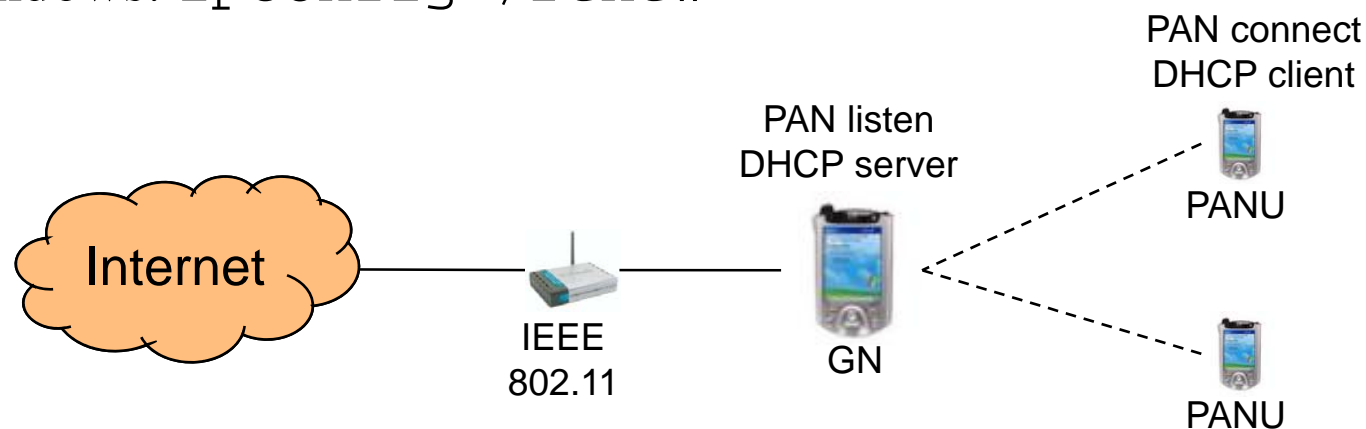



Conclusions & Ongoing Work

- MMHC supports **multi-hop multi-path** spontaneous connectivity exploiting off-the-shelf **heterogeneous equipment**
 - IEEE 802.11, Bluetooth, Ethernet
- Bluetooth effective exploitation via
 - **efficient inquiry** procedure to discover devices
 - **homogeneous access** to heterogeneous drivers
- **JSR-82 enhancement** to
 - **gather RSSI**, required to estimate node mobility
 - **provide BNEP** connections, to easily support IP connectivity
- Ongoing work
 - additional efforts to fully support MS Windows drivers
 - **QoS** issues: multi-hop connectivity **starvation avoidance** via dynamic and context-aware bandwidth reservation
 - **security** issues: peer mutual authentication, user incentives, dynamic level of trust management



Any question?



- Prototype code and implementation insights:
 - <http://lia.deis.unibo.it/research/MAC/>
 - <http://lia.deis.unibo.it/research/MACHINE/>
 - <http://lia.deis.unibo.it/research/MMHC/>
 - <http://lia.deis.unibo.it/Staff/CarloGiannelli/>